

DETAIL POLE ASSEMBLY

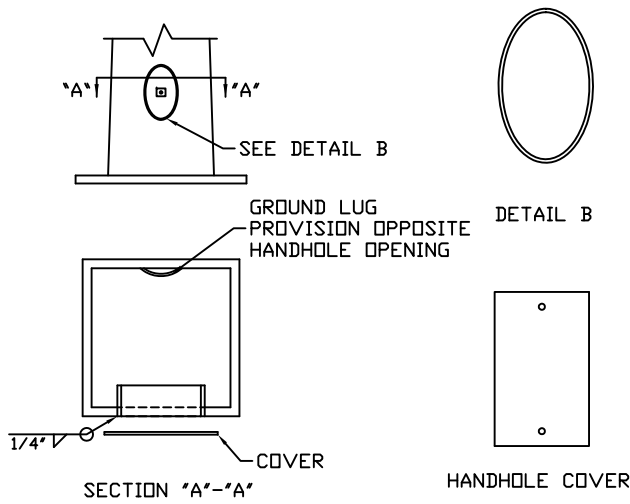

DETAIL 3 TYPICAL HANDHOLE

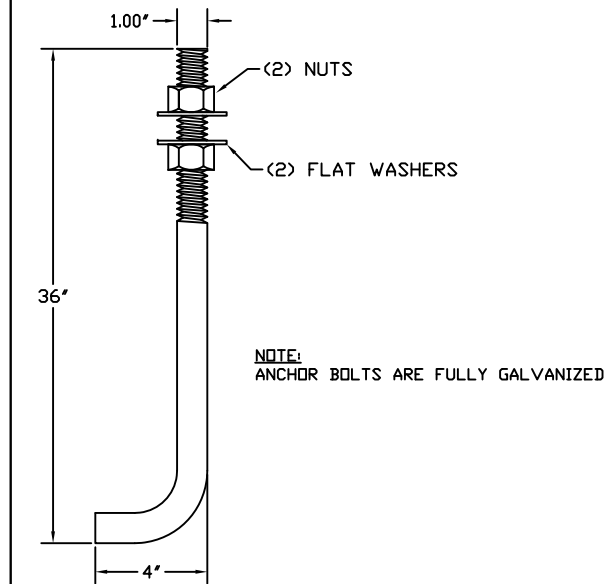

DETAIL 1 ANCHOR BOLTS

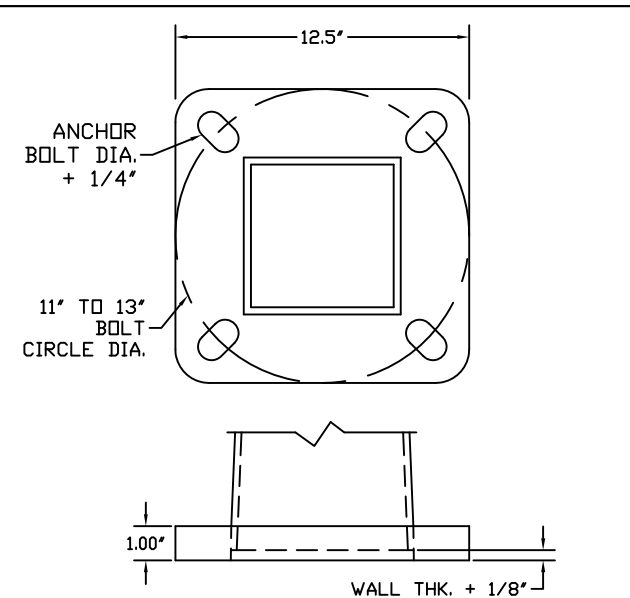

DETAIL 4 BASE PLATE

COMPONENT	SPECIFICATION
POLE SHAFT	ASTM A500 GR.B
MISC. STEEL	ASTM A36
ANCHOR BOLTS	ASTM F1554 GR. 55
BASE PLATE	ASTM A36

GENERAL NOTES:

1. ALL HARDWARE TO BE GALVANIZED TO ASTM A153.
2. POLE ASSEMBLY TO BE GALVANIZED TO ASTM A123.
3. ALL WELDING TO CONFORM TO AWS D1.1 MOST RECENT EDITION.
4. DESIGN INCORPORATE GUST FACTOR PER REF CODE.
5. REFER TO GENERAL INSTALLATION INSTRUCTIONS PRIOR TO ASSEMBLY.

FINISH:	WIND SPEED:	DESIGN CRITERIA:
<input type="checkbox"/> GALVANIZED	<input type="checkbox"/> 80 MPH <input type="checkbox"/> 110 MPH	<input type="checkbox"/> AASHTO LTS 3 <input type="checkbox"/> ASCE
<input type="checkbox"/> PAINTED	<input type="checkbox"/> 90 MPH <input type="checkbox"/> 120 MPH	<input checked="" type="checkbox"/> AASHTO LTS 6 <input type="checkbox"/> DSA
<input type="checkbox"/> PAINTED & GALV	<input type="checkbox"/> 100 MPH <input type="checkbox"/> ___ MPH	<input type="checkbox"/> IBC <input type="checkbox"/> UBC

LOADING DATA			
90 MPH	100 MPH	110 MPH	120 MPH
22 EPA	16 EPA	12 EPA	8 EPA
550 LBS	400 LBS	300 LBS	200 LBS

DETAIL 2 MATERIAL SPECIFICATIONS



Makers Sales and Marketing, LLC

2316 WEAVER ST.
HALTOM CITY, TX 76117
METRO (817) 834-5538
TOLL FREE (866) 724-4527
FAX (817) 831-6088

DATE:	REV.:	JOB NO.	SCALE:
	00	N/A	NTS
DRAWING NUMBER:	DRAWN BY:	QUOTE NUMBER:	
MSNH2560ABH	DR	N/A	