

DETAIL POLE ASSEMBLY

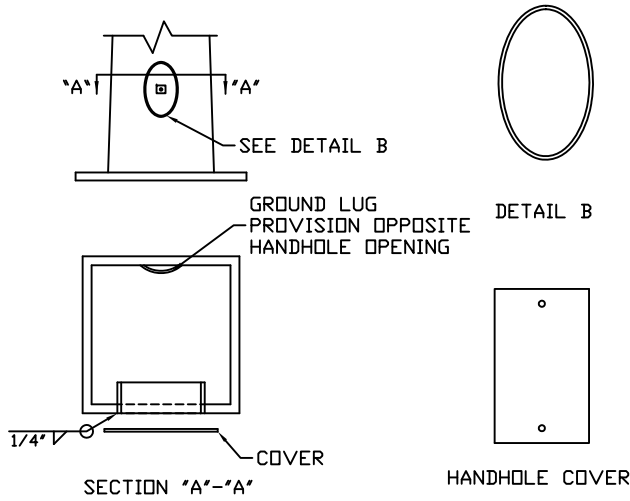

DETAIL 3 TYPICAL HANDHOLE

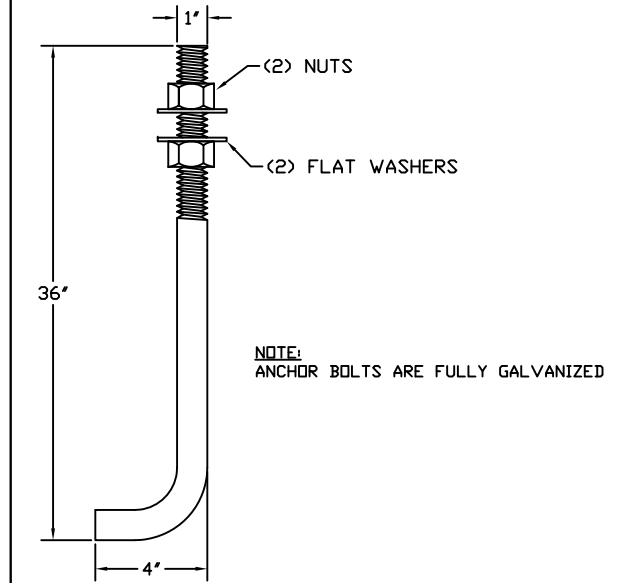

DETAIL 1 ANCHOR BOLTS

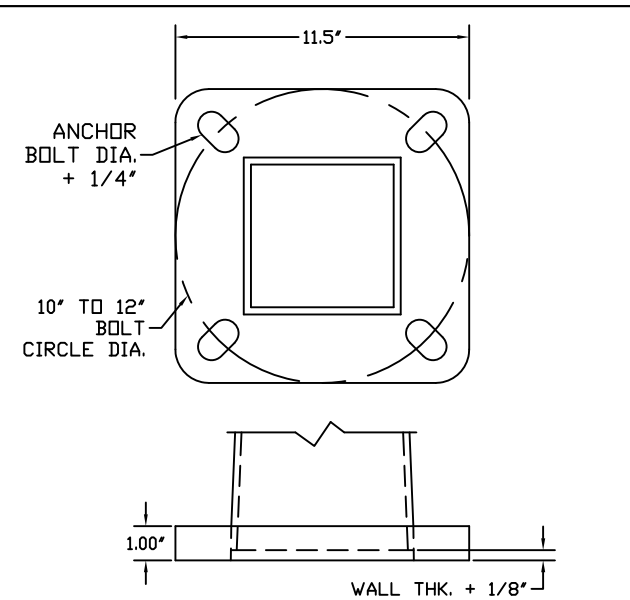

DETAIL 4 BASE PLATE

COMPONENT	SPECIFICATION
POLE SHAFT	ASTM A500 GR.B
MISC. STEEL	ASTM A36
ANCHOR BOLTS	ASTM F1554 GR. 55
BASE PLATE	ASTM A36

GENERAL NOTES:

1. ALL HARDWARE TO BE GALVANIZED TO ASTM A153.
2. POLE ASSEMBLY TO BE GALVANIZED TO ASTM A123.
3. ALL WELDING TO CONFORM TO AWS D1.1 MOST RECENT EDITION.
4. DESIGN INCORPORATE GUST FACTOR PER REF CODE.
5. REFER TO GENERAL INSTALLATION INSTRUCTIONS PRIOR TO ASSEMBLY.

FINISH:

- GALVANIZED 80 MPH 110 MPH AASHTO LTS 3 ASCE
 PAINTED 90 MPH 120 MPH AASHTO LTS 6 DSA
 PAINTED & GALV 100 MPH ___ MPH IBC UBC

LOADING DATA

90 MPH	100 MPH	110 MPH	120 MPH
26 EPA	20 EPA	16 EPA	13 EPA
650 LBS	500 LBS	400 LBS	325 LBS

DETAIL 2 MATERIAL SPECIFICATIONS



2316 WEAVER ST.
 HALTOM CITY, TX 76117
 METRO (817) 834-5538
 TOLL FREE (866) 724-4527
 FAX (817) 831-6088

DATE:	REV.:	JOB NO.	SCALE:
	00	N/A	NTS
DRAWING NUMBER:		DRAWN BY:	QUOTE NUMBER:
MSNH2050ABH		DR	N/A