

DETAIL POLE ASSEMBLY

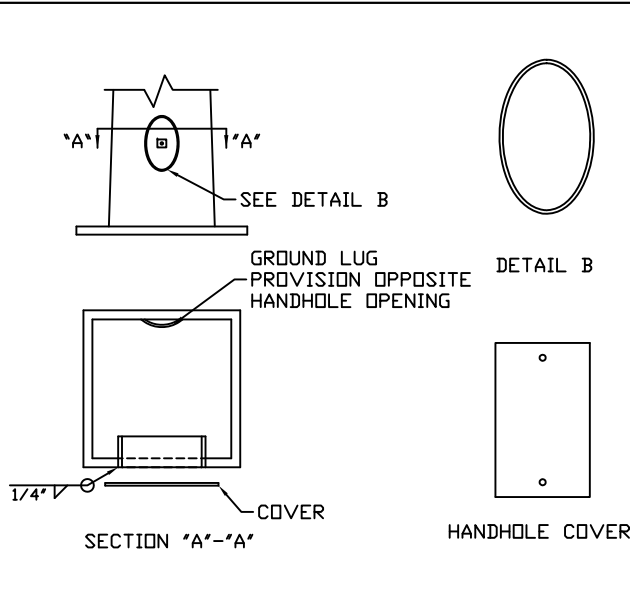

DETAIL 3 TYPICAL HANDHOLE

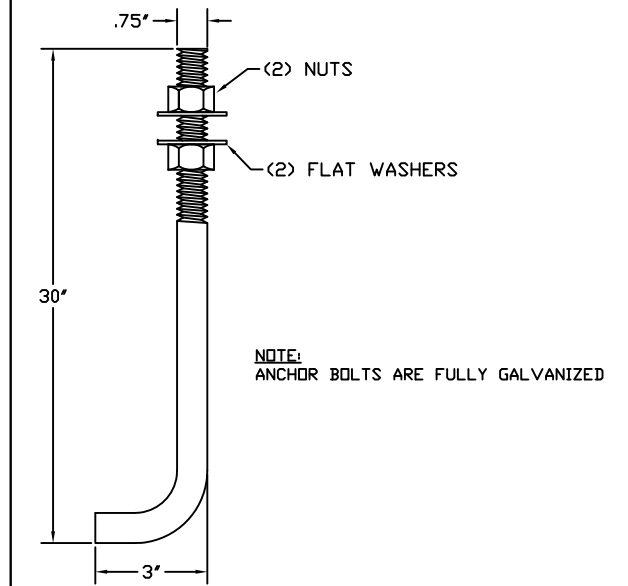

DETAIL 1 ANCHOR BOLTS

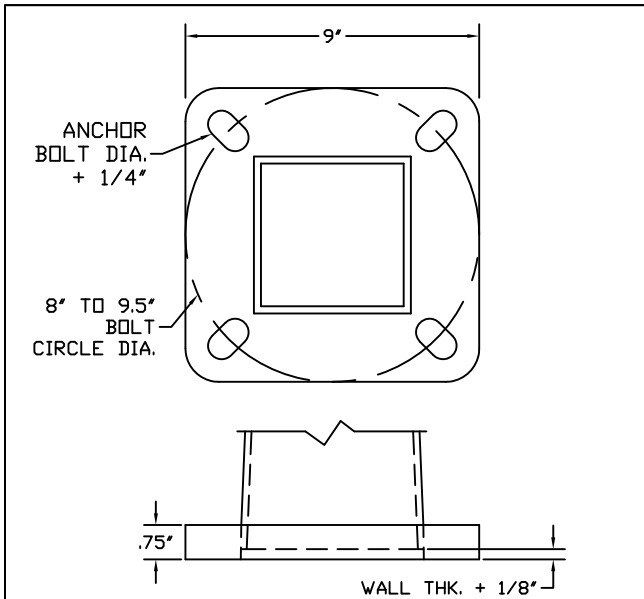

DETAIL 4 BASE PLATE

COMPONENT	SPECIFICATION
POLE SHAFT	ASTM A500 GR.B
MISC. STEEL	ASTM A36
ANCHOR BOLTS	ASTM F1554 GR. 55
BASE PLATE	ASTM A36

GENERAL NOTES:

1. ALL HARDWARE TO BE GALVANIZED TO ASTM A153.
2. POLE ASSEMBLY TO BE GALVANIZED TO ASTM A123.
3. ALL WELDING TO CONFORM TO AWS D1.1 MOST RECENT EDITION.
4. DESIGN INCORPORATE GUST FACTOR PER REF CODE.
5. REFER TO GENERAL INSTALLATION INSTRUCTIONS PRIOR TO ASSEMBLY.

FINISH:

- GALVANIZED     80 MPH     110 MPH     AASHTO LTS 3     ASCE  
 PAINTED         90 MPH     120 MPH     AASHTO LTS 6     DSA  
 PAINTED & GALV    100 MPH    \_\_\_ MPH     IBC                     UBC

LOADING DATA

90 MPH	100 MPH	110 MPH	120 MPH
15 EPA	11 EPA	9 EPA	6 EPA
375 LBS	275 LBS	225 LBS	150 LBS

DETAIL 2 MATERIAL SPECIFICATIONS



2316 WEAVER ST.  
 HALTOM CITY, TX 76117  
 METRO (817) 834-5538  
 TOLL FREE (866) 724-4527  
 FAX (817) 831-6088

DATE:	REV.:	JOB NO.:	SCALE:
	00	N/A	NTS
DRAWING NUMBER:		DRAWN BY:	QUOTE NUMBER:
MSNH2040ABH		DR	N/A