

DETAIL 1 POLE ASSEMBLY

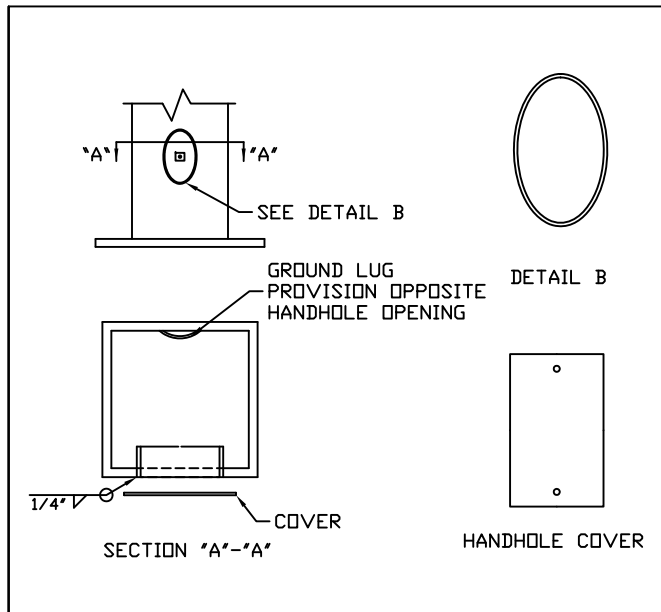

DETAIL 3 TYPICAL HANDHOLE

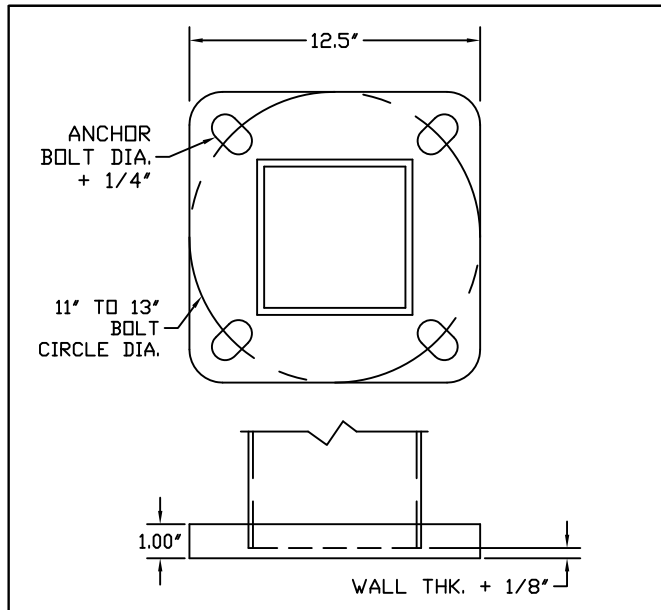

DETAIL 4 BASE PLATE

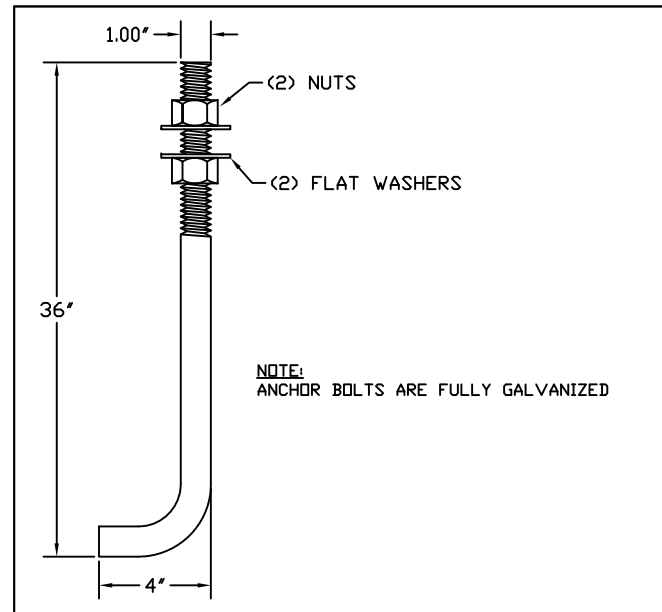

DETAIL 1 ANCHOR BOLTS

COMPONENT	SPECIFICATION
POLE SHAFT	ASTM A500 GR.B
MISC. STEEL	ASTM A36
ANCHOR BOLTS	ASTM F1554 GR. 55
BASE PLATE	ASTM A36

- GENERAL NOTES:
1. ALL HARDWARE TO BE GALVANIZED TO ASTM A153.
 2. POLE ASSEMBLY TO BE GALVANIZED TO ASTM A123.
 3. ALL WELDING TO CONFORM TO AWS D1.1 MOST RECENT EDITION.
 4. DESIGN INCORPORATE GUST FACTOR PER REF CODE.
 5. REFER TO GENERAL INSTALLATION INSTRUCTIONS PRIOR TO ASSEMBLY.
- FINISH: WIND SPEED: DESIGN CRITERIA:
- GALVANIZED 80 MPH 110 MPH AASHTO LTS 3 ASCE
 PAINTED 90 MPH 120 MPH AASHTO LTS 6 DSA
 PAINTED & GALV 100 MPH ___ MPH IBC UBC

LOADING DATA			
90 MPH	100 MPH	110 MPH	120 MPH
9 EPA	5 EPA	3 EPA	N/A
225 LBS	125 LBS	75 LBS	N/A

DETAIL 2 MATERIAL SPECIFICATIONS



2316 WEAVER ST.
 HALTOM CITY, TX 76117
 METRO (817) 834-5538
 TOLL FREE (866) 724-4527
 FAX (817) 831-6088

DATE:	REV.:	JOB NO.:	SCALE:
	00	N/A	NTS
DRAWING NUMBER:	DRAWN BY:	QUOTE NUMBER:	
MSN4060ABH	DR	N/A	