

DETAIL 2 POLE ASSEMBLY

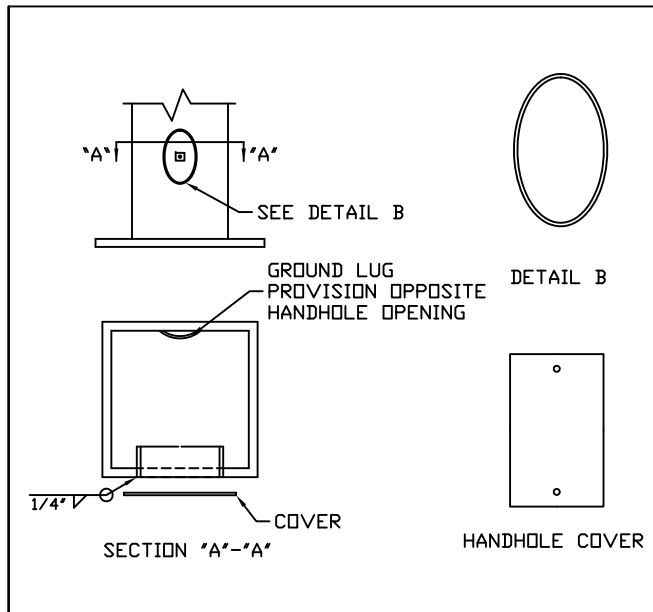

DETAIL 3 TYPICAL HANDHOLE

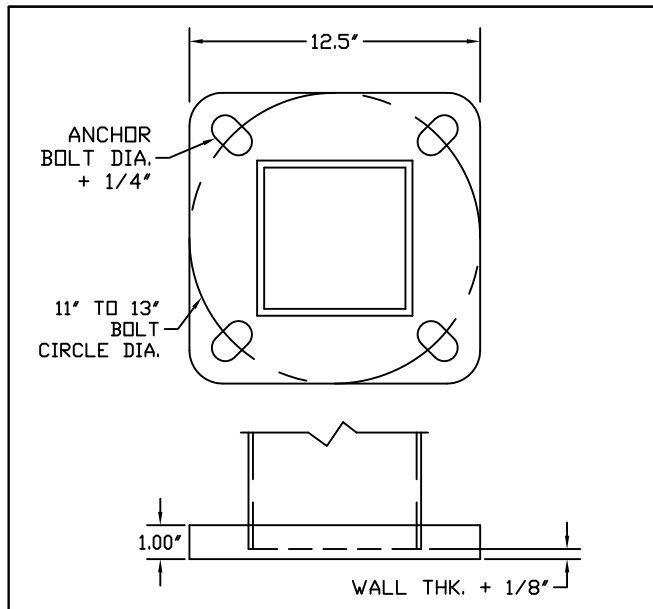

DETAIL 4 BASE PLATE

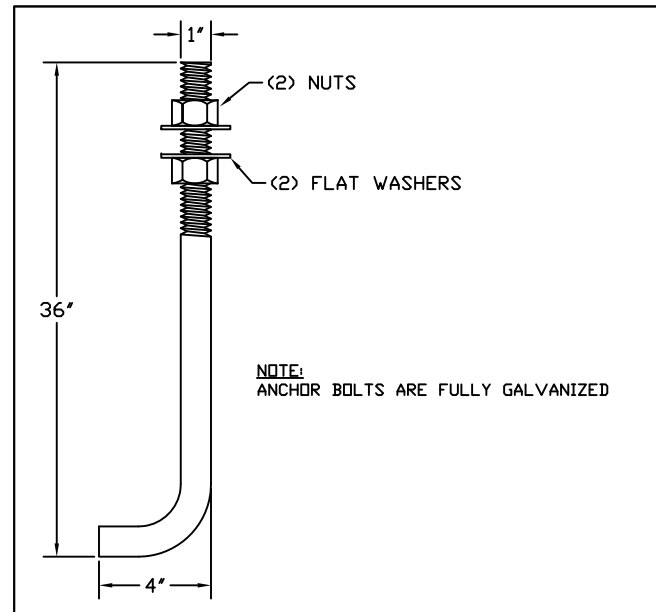

DETAIL 1 ANCHOR BOLTS

COMPONENT	SPECIFICATION
POLE SHAFT	ASTM A500 GR.B
MISC. STEEL	ASTM A36
ANCHOR BOLTS	ASTM F1554 GR. 55
BASE PLATE	ASTM A36

- GENERAL NOTES:**
1. ALL HARDWARE TO BE GALVANIZED TO ASTM A153.
 2. POLE ASSEMBLY TO BE GALVANIZED TO ASTM A123.
 3. ALL WELDING TO CONFORM TO AWS D1.1 MOST RECENT EDITION.
 4. DESIGN INCORPORATE GUST FACTOR PER REF CODE.
 5. REFER TO GENERAL INSTALLATION INSTRUCTIONS PRIOR TO ASSEMBLY.
- FINISH:**
- GALVANIZED PAINTED PAINTED & GALV
- WIND SPEED:**
- 80 MPH 90 MPH 100 MPH 110 MPH 120 MPH ___ MPH
- DESIGN CRITERIA:**
- AASHTO LTS 3 ASCE AASHTO LTS 6 DSA IBC UBC

LOADING DATA			
90 MPH	100 MPH	110 MPH	120 MPH
22 EPA	16 EPA	12 EPA	8 EPA
550 LBS	400 LBS	300 LBS	200 LBS

DETAIL 2 MATERIAL SPECIFICATIONS



2316 WEAVER ST.
 HALTOM CITY, TX 76117
 METRO (817) 834-5538
 TOLL FREE (866) 724-4527
 FAX (817) 831-6088

DATE:	REV.:	JOB NO.:	SCALE:
	00	N/A	NTS
DRAWING NUMBER:	DRAWN BY:	QUOTE NUMBER:	
MSN2560ABH	DR	N/A	