

DETAIL POLE ASSEMBLY

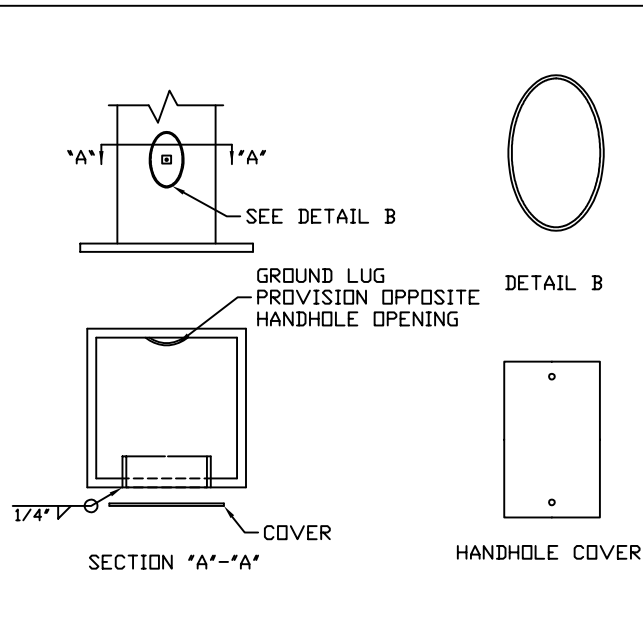

DETAIL 3 TYPICAL HANDHOLE

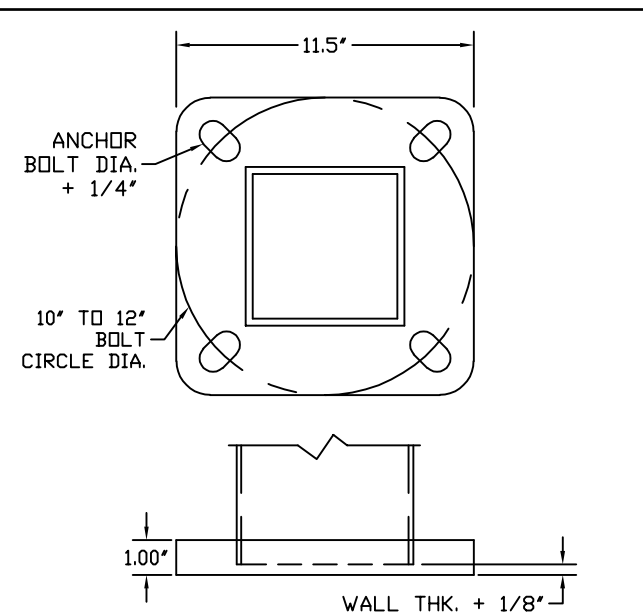

DETAIL 4 BASE PLATE

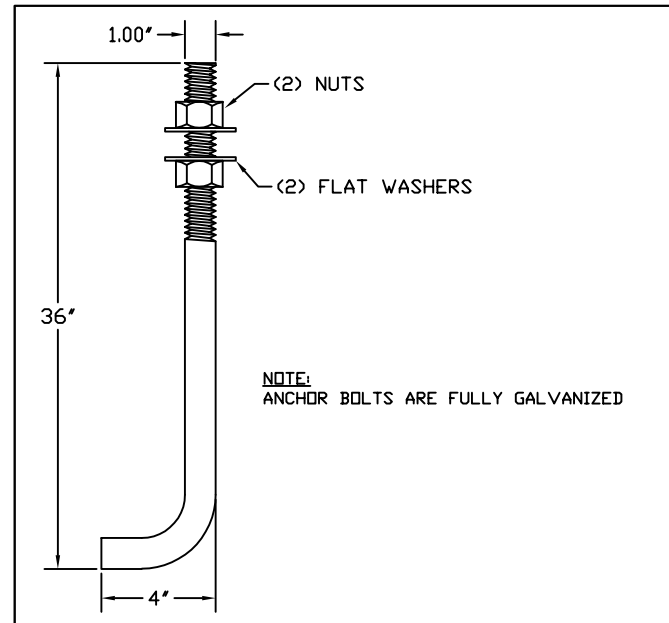

DETAIL 1 ANCHOR BOLTS

NOTE:
ANCHOR BOLTS ARE FULLY GALVANIZED

COMPONENT	SPECIFICATION
POLE SHAFT	ASTM A500 GR.B
MISC. STEEL	ASTM A36
ANCHOR BOLTS	ASTM F1554 GR. 55
BASE PLATE	ASTM A36

GENERAL NOTES:

1. ALL HARDWARE TO BE GALVANIZED TO ASTM A153.
2. POLE ASSEMBLY TO BE GALVANIZED TO ASTM A123.
3. ALL WELDING TO CONFORM TO AWS D1.1 MOST RECENT EDITION.
4. DESIGN INCORPORATE GUST FACTOR PER REF CODE.
5. REFER TO GENERAL INSTALLATION INSTRUCTIONS PRIOR TO ASSEMBLY.

FINISH:	WIND SPEED:	DESIGN CRITERIA:
<input type="checkbox"/> GALVANIZED	<input type="checkbox"/> 80 MPH <input type="checkbox"/> 110 MPH	<input type="checkbox"/> AASHTO LTS 3 <input type="checkbox"/> ASCE
<input type="checkbox"/> PAINTED	<input type="checkbox"/> 90 MPH <input type="checkbox"/> 120 MPH	<input checked="" type="checkbox"/> AASHTO LTS 6 <input type="checkbox"/> DSA
<input type="checkbox"/> PAINTED & GALV	<input type="checkbox"/> 100 MPH <input type="checkbox"/> ___ MPH	<input type="checkbox"/> IBC <input type="checkbox"/> UBC

LOADING DATA			
90 MPH	100 MPH	110 MPH	120 MPH
17 EPA	13 EPA	9 EPA	7 EPA
425 LBS	325 LBS	225 LBS	175 LBS

DETAIL 2 MATERIAL SPECIFICATIONS



2316 WEAVER ST.
HALTOM CITY, TX 76117
METRO (817) 834-5538
TOLL FREE (866) 724-4527
FAX (817) 831-6088

DATE:	REV.: 00	JOB NO.: N/A	SCALE: NTS
DRAWING NUMBER: MSN2550ABH	DRAWN BY: DR	QUOTE NUMBER: N/A	