

DETAIL 1 POLE ASSEMBLY

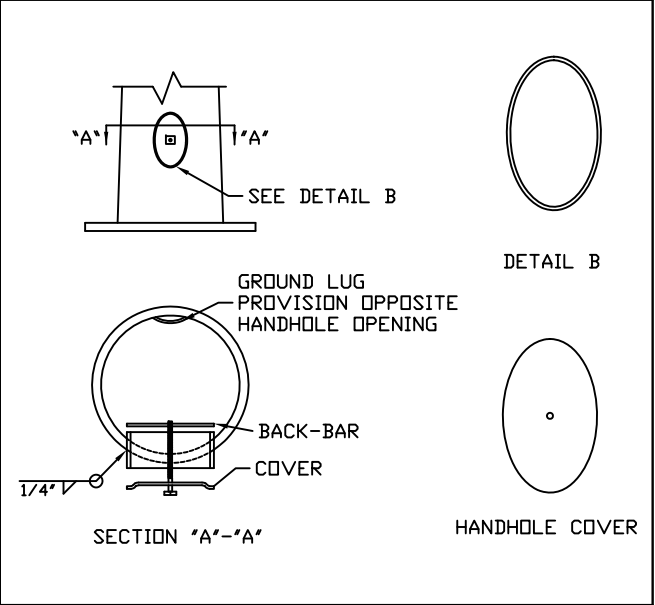

DETAIL 3 TYPICAL HANDHOLE

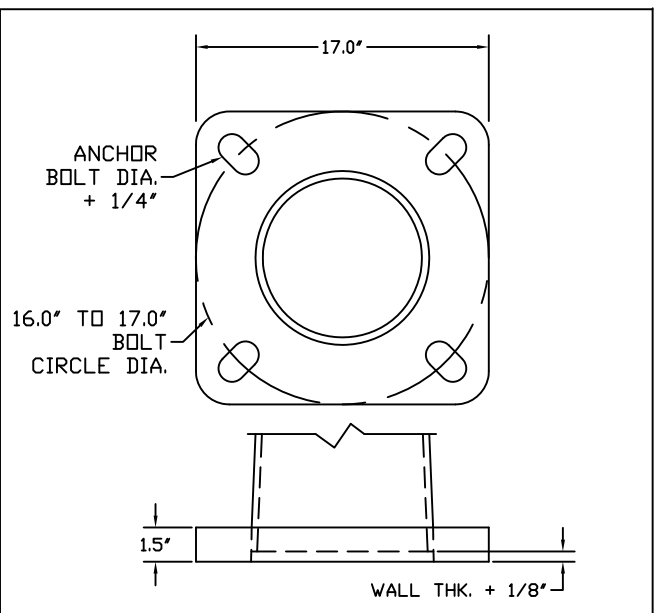

DETAIL 4 BASE PLATE

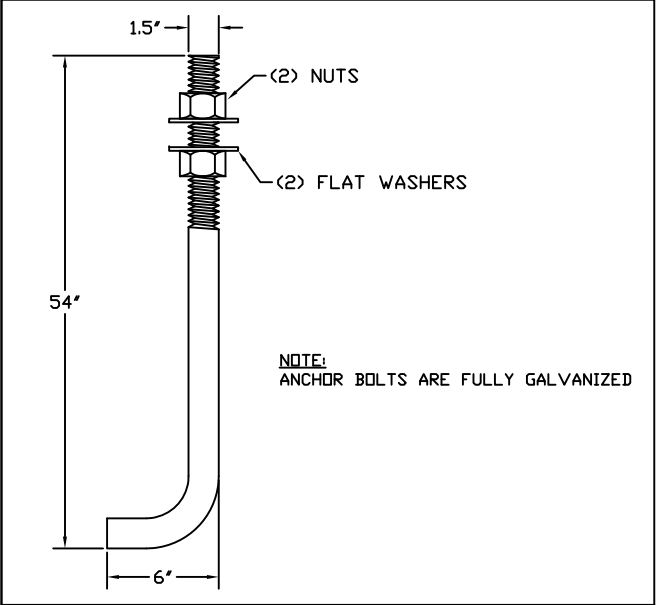

DETAIL 1 ANCHOR BOLTS

COMPONENT	SPECIFICATION
POLE SHAFT	ASTM A500 GR.B
MISC. STEEL	ASTM A36
ANCHOR BOLTS	ASTM F1554 GR. 55
BASE PLATE	ASTM A36

- GENERAL NOTES:**
1. ALL HARDWARE TO BE GALVANIZED TO ASTM A153.
 2. POLE ASSEMBLY TO BE GALVANIZED TO ASTM A123.
 3. ALL WELDING TO CONFORM TO AWS D1.1 MOST RECENT EDITION.
 4. DESIGN INCORPORATE GUST FACTOR PER REF CODE.
 5. REFER TO GENERAL INSTALLATION INSTRUCTIONS PRIOR TO ASSEMBLY.
- FINISH:**
 GALVANIZED
 PAINTED
 PAINTED & GALV
- WIND SPEED:**
 80 MPH
 90 MPH
 100 MPH
 ___ MPH
- DESIGN CRITERIA:**
 AASHTO LTS 3
 AASHTO LTS 6
 IBC
 ASCE
 DSA
 UBC

LOADING DATA			
90 MPH	100 MPH	110 MPH	120 MPH
38 EPA	31 EPA	25 EPA	20 EPA
950 LBS	775 LBS	625 LBS	500 LBS

DETAIL 2 MATERIAL SPECIFICATIONS



2316 WEAVER ST.
 HALTOM CITY, TX 76117
 METRO (817) 834-5538
 TOLL FREE (866) 724-4527
 FAX (817) 831-6088

DATE:	REV.:	JOB NO.:	SCALE:
	00	N/A	NTS
DRAWING NUMBER:		QUOTE NUMBER:	
MRT5012ABH		N/A	

DATE:	REV.:	JOB NO.:	SCALE:
	00	N/A	NTS
DRAWING NUMBER:		QUOTE NUMBER:	
MRT5012ABH		N/A	